

REVISIONS				
S/N	DESCRIPTION	BY	APP	DATE
A	ADDED METRIC DIMENSIONS	RL	BT	1/06/15

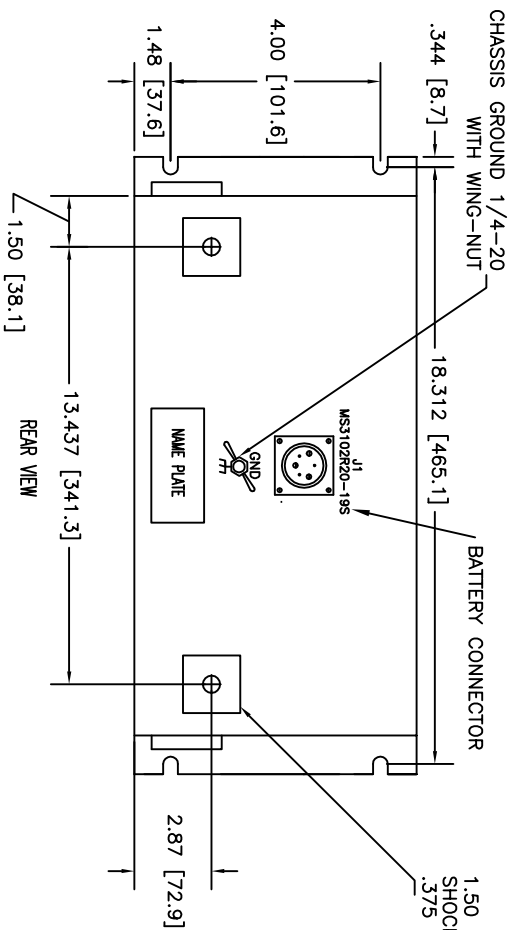
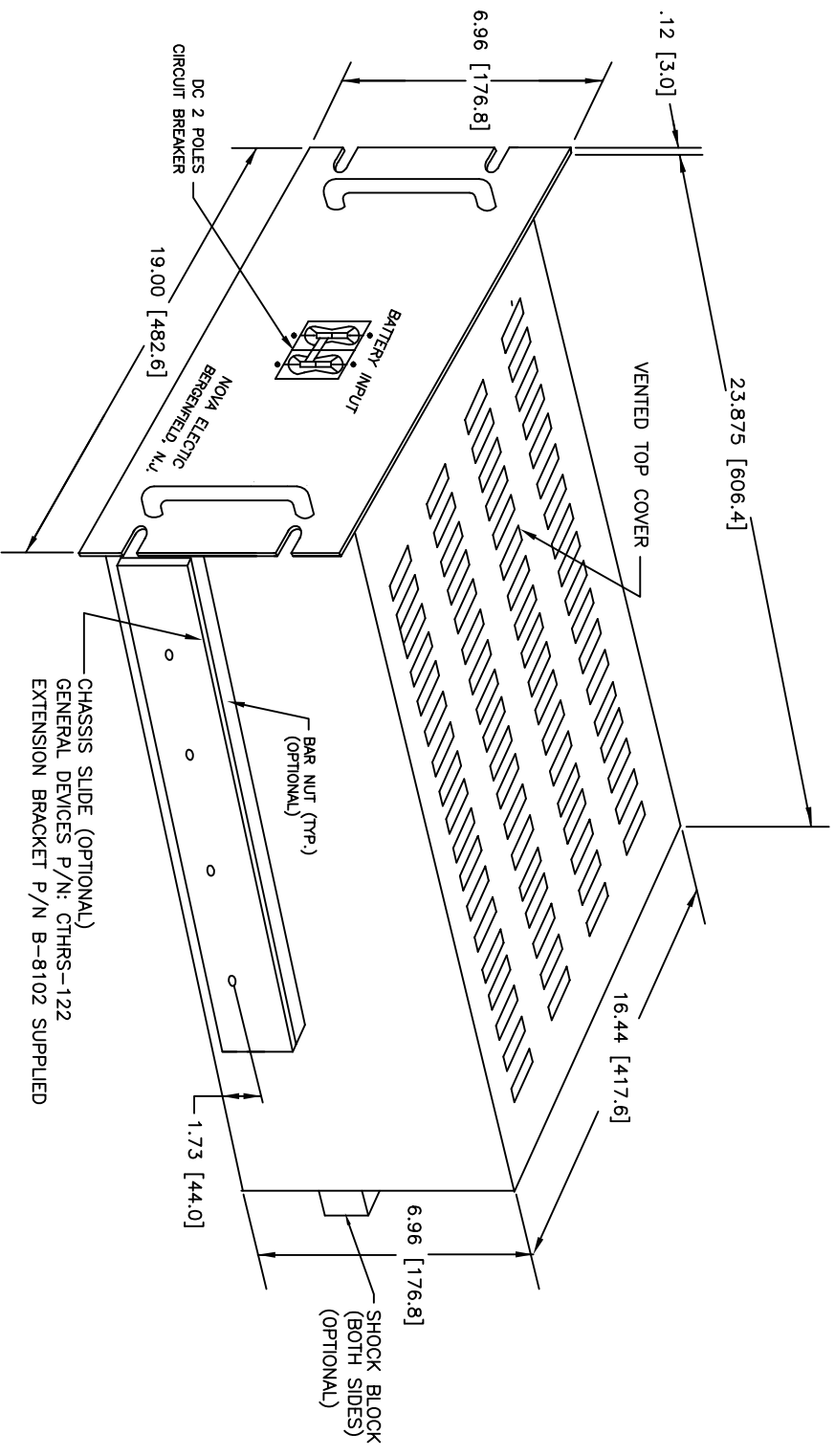

1.50 [38.1] X 1.50 [38.1] X 1.00 [25.4] THK.  
SHOCK BLOCK MOUNTED TO EXTERIOR SURFACE  
.375 [9.5] DIA PIN SUPPLIED (2) PLS  
(OPTIONAL)

NOTES:

1. ALL DIMENSIONS ARE IN INCHES AND MILLIMETERS [mm].
2. EXTERIOR ANSIS# 61 GRAY SEMI-GLOSS
3. AIR INTAKE HOLES ON CHASSIS BOTTOM.
4. HANDLES PROJECT 1.50 INCHES FROM PANEL SURFACE.
5. APPROXIMATE WEIGHT: 250 LBS.
6. BATTERY TYPE: 12V, 17AH/20HR SEALED MAINTENANCE-FREE, RECHARGABLE--QTY 16.

UNLESS OTHERWISE SPECIFIED: DIMENSIONS ARE IN INCHES FRACTIONS DECIMALS ANGLES X.XX = .02 ±.1 °		THIS DRAWING CONTAINS PROPERTY INFORMATION AND MAY NOT BE REPRO- DUCED WITHOUT THE PER- MISSION OF NOVA ELECTRIC.		NOVA ELECTRIC A DIV. OF TECHNOLOGY DYNAMICS INC. 100 SCHOOL STREET BERGENFIELD, N.J. 07621-2915	
MATERIAL:	DATE:	DATE:	TITLE:	SCALE:	DATE:
	10/23/03	10/23/03	BATTERY PACK	1/1	10/23/03
FINISH:	CHECKED:	APPROVED:	SIZE:	CAGE:	REV:
		10/23/03	A	29019	A
HTTP://WWW.NOVAELECTRIC.COM					
					SHEET 1 OF 1